

Local Development Plan - Site Specific Building Requirements

This Local Development Plan (LDP) replaces the Site-Specific Building Requirements of the Port Coogee Marina Village Built Form Codes (PCMBVFC) to the extent identified below in relation to Site 7 for the coverage of lots 1-17 only.

All other elements of the City of Cockburn's relevant Local Planning Scheme, Planning Policies, PCMBVFC and Port Coogee Marina Village Design Guidelines – Omeo Peninsula (DG) apply to the lots contained upon this LDP where not varied in the following provisions. The Residential Design Codes (RDC 7.3 Volume 1) do not apply, except for providing definitions of terms only.

Where there is any inconsistency between this LDP, the PCMBVFC and DG's, the LDP shall prevail.

Note: All lots contained within this LDP are subject to a Development Application and subsequent approval by the City of Cockburn.

Deemed to Comply Provisions																			
Street Setbacks & Lot Boundary Setbacks for all building(s)																			
Basement:	All boundaries:	<ul style="list-style-type: none"> 0.0m minimum permitted. 																	
All levels (above ground):	Primary Street: Napoleon Parade	<ul style="list-style-type: none"> 2.5m minimum* / 4.0m maximum. 																	
	Secondary Street: Lot 1 (Chieftain Esplanade), Lot 9 and Lot 10 (Saxon Lane) and Lot 17 (Opal Lane):	<ul style="list-style-type: none"> 1.0m minimum* / 4.0m maximum setback applicable to 50% of the total side building length, commencing at the primary street setback. 1.0m minimum* / no maximum setback applies to the remaining 50% of the building length. 																	
	Lot side boundaries: (other than secondary street/laneway):	<ul style="list-style-type: none"> Boundary walls: Nil setback (0.0m) permitted to all levels (to a maximum building height of 3 storeys) for a maximum length determined by the front and rear setbacks (incorporating projections into the front setback where permitted – n.b. front projections permitted as detailed below), only when any exposed parapet wall on a common boundary is suitably finished to match the external walls of the building, unless otherwise approved by the city. Non boundary walls: Building to be setback 1.0m minimum* for ground level building, 1.5m minimum* for level 2 and 3.0m minimum* for level 3 (no maximums). 																	
Projections (all levels):	Primary Street: Napoleon Parade:	<ul style="list-style-type: none"> Balconies and architectural elements may project into the primary street setback area to a minimum setback of 1.0m from the street boundary. Balcony projections can include their support structures (parapet walls and columns). 																	
	Laneway: Liberty Vista	<ul style="list-style-type: none"> All lots: No obstructions are permitted within the laneway setback i.e., Gas meter pillar. 																	
Ground level:	Garages:	<ul style="list-style-type: none"> Lot 1: 4.4m mandatory (measured along western lot boundary). Lot 2: 1.5m mandatory (measured along western lot boundary). Lot 3: 1.0m mandatory (measured along western lot boundary). Lots 4-16: 1.0m mandatory. Lot 17: 1.8m mandatory. 																	
		Dwelling, fencing and other building:	<ul style="list-style-type: none"> Lots 1-8 and 11-16: 0.8m minimum* / no maximum - setback distance measured from garage façade and must not encroach into Landscape Zone. Lots 9-10 and 17: 3.0m minimum* / no maximum - setback from rear laneway boundary (Liberty Vista) and must not encroach into Landscape Zone. 																
Second level:	Laneway: Liberty Vista	<ul style="list-style-type: none"> All lots: Second level building is permitted to cantilever over the landscape zone for the extent permitted by setbacks below. Lot 1: 4.4m mandatory (measured along western lot boundary). Lot 2: 1.5m minimum* / no maximum (measured along western lot boundary). Lot 3: 1.0m minimum* / no maximum (measured along western lot boundary). Lots 4-8 and 11-16: 1.0m minimum* / no maximum. Lots 9-10: 1.0m mandatory setback for building above garage; 1.0m minimum* / 3.0m maximum setback for building above Landscape Zone. Lot 17: 1.8m mandatory setback for building above garage; 1.8m minimum* / 3.0m maximum setback for building above Landscape Zone. 																	
Third level:	Laneway: Liberty Vista	<ul style="list-style-type: none"> All lots: Third level building is permissible, but not required above garage, and is permitted to cantilever over the landscape zone for the extent permitted by setbacks below. Lot 1: 4.4m minimum* / no maximum (measured along western lot boundary). Lot 2: 1.5m minimum* / no maximum (measured along western lot boundary). Lot 3: 1.0m minimum* / no maximum (measured along western lot boundary). Lots 4-16: 1.0m minimum* / no maximum. Lot 17: 1.8m minimum* / no maximum. 																	
<p>Note: *. Averaging of all minimum setbacks identified above is not permitted. Note: All building frontages shall be articulated to all perimeter street frontages. Note: Boundary wall refers to a wall on, or less than 600mm from any lot boundary, other than a street boundary.</p>																			
Building Height:	All Lots:	<ul style="list-style-type: none"> For all lots, a minimum three (3) storey building height applies to the primary street frontage and a portion of the secondary street frontage where applicable (refer LDP Design Rationale attachment). For corner lots 1, 9, 10, and 17, a minimum two (2) storey building height applies to the remaining secondary street frontage and laneway frontage(s) (refer LDP Design Rationale attachment). A minimum one (1) storey building height is permitted to remaining portions of the building for these lots that are not visible from any street frontage. For remaining lots 2-8 and 11-16 a minimum one (1) storey building height is permitted to portions of the building that are visible from the laneway only. A loft will not be deemed to satisfy the 3-storey building height requirement. A maximum total building height of 13.6m above the finished design surface is permitted on the lot, with lift overruns and roof terraces permitted where they are contained within the maximum building height (13.6m). A minimum ground level building floor to floor height of 3.0m applies (measured from slab to slab). No minimum building floor to floor level heights apply to the second storey and above. <p>Note: Maximum total building height incorporates all walls, roof elements, functional utilities, external fixtures, solar collectors, lift overruns, but excludes minor projections which are permitted above total building height.</p>																	
Floor Area		<ul style="list-style-type: none"> For prominent corner lots 1, 9, 10, and 17, the third storey must have a minimum floor area of 40m² and be no less than 10m in depth (not inclusive of balcony). Major openings from active habitable rooms are to be oriented to both the primary street and secondary street. For remaining lots, the third storey must have a minimum floor area of 24m² and be no less than 6m in depth (not inclusive of balcony). A major opening from an active habitable room is to be oriented to the primary street. 																	
Street Surveillance		<ul style="list-style-type: none"> The primary street frontage shall provide access to the major entry (front door) of the building(s). At least one major opening from a habitable room of the dwelling (at each level) shall achieve passive surveillance of the adjacent primary and secondary streets (where applicable). For corner lots 1, 9, 10, and 17, at least one major opening from a habitable room of the dwelling above the garage shall achieve passive surveillance of the adjacent laneway. The location of major openings at the ground level shall align with the visually permeable component of developer provided fencing design. 																	
Open Space Requirements		<ul style="list-style-type: none"> For all single house and grouped dwelling development, the Open Space and Landscape 'must have' provisions of the PCMBVFC are amended by the below 'must have's': <ul style="list-style-type: none"> Provide a minimum 15% of each lot area (minimum dimension of 1.0m) as Soft Landscape Area consisting of a range of groundcovers, shrubs and trees in accordance with a landscaping plan. Soft Landscape Area will be permitted on an upper building level(s) (i.e., green roof). Soft Landscape Area may incorporate limited areas of permeable paving (maximum 33%). Provide a Deep Soil Area (minimum dimension 1.5m) and associated tree requirement (Small Tree – mature size of 2.6m canopy and 3.8m height). Deep Soil Area may form part of the minimum Soft Landscape Area requirement or be satisfied by the Designated Landscape Zone. At least one Outdoor Living Area (OLA) shall be provided in accordance with the following minimum requirements: 																	
		<table border="1"> <thead> <tr> <th>Location</th> <th>Minimum Dimension</th> <th>Minimum Area</th> <th>Maximum permanent roof cover</th> <th>Directly Accessible from a Habitable Room</th> <th>Permitted Within Street/POS Setback</th> </tr> </thead> <tbody> <tr> <td>Ground Floor</td> <td>3.0m</td> <td>16m²</td> <td>50%</td> <td>Yes</td> <td>Yes</td> </tr> <tr> <td>Upper Levels</td> <td>2.7m</td> <td>16m²</td> <td>100%</td> <td>Yes</td> <td>Yes</td> </tr> </tbody> </table>	Location	Minimum Dimension	Minimum Area	Maximum permanent roof cover	Directly Accessible from a Habitable Room	Permitted Within Street/POS Setback	Ground Floor	3.0m	16m ²	50%	Yes	Yes	Upper Levels	2.7m	16m ²	100%	Yes
Location	Minimum Dimension	Minimum Area	Maximum permanent roof cover	Directly Accessible from a Habitable Room	Permitted Within Street/POS Setback														
Ground Floor	3.0m	16m ²	50%	Yes	Yes														
Upper Levels	2.7m	16m ²	100%	Yes	Yes														
Vehicular Access		<ul style="list-style-type: none"> Designated garage locations and setbacks on the LDP are mandatory and all lots shall achieve vehicle access from the laneway. A maximum driveway crossover width of 6.0m applies, and paving material shall correspond with the adjoining laneway material, for all lots. Car parking and manoeuvring shall be provided in accordance with AS2890.1 (as amended). 																	
Street Walls and Fences		<ul style="list-style-type: none"> Where fencing is provided by the developer, no modifications are to occur, aside from maintenance and repair in materials that are substantially identical to those used in the original construction. This includes those lots with stair access. Any fencing proposed where not provided by the developer, including fencing on top of a retaining wall, shall be in accordance with specifications detailed in the applicable Port Coogee Marina Village Design Guidelines. Non-Estate fencing must not encroach into a Designated Landscape Zone and shall be setback from the laneway (Liberty Vista) the equivalent of the Landscape Zone dimension. 																	
External Fixtures, Utilities and Facilities		<ul style="list-style-type: none"> Plant and Machinery: The development plans shall demonstrate the following items can be accommodated now or in the future without being visible from the public realm and adjacent neighbour development: Air-conditioning condenser units; hot water system and pumps. Where these items are required on roof tops, they shall be fully concealed from view by adjacent overlooking development. 																	
Site Works		<ul style="list-style-type: none"> Finished ground floor levels must be within 0.25m of the finished design surface of the lot. No brick build-up or additional fill will be permitted for dwelling construction. 																	

Port Coogee Marina Village Design Elements (single house)	
When assessing building/development applications within this LDP, the City will have regard to the following additional design elements:	
Façade Design (All road frontages)	<ul style="list-style-type: none"> The design of a building must address all adjacent streets (primary and secondary) and laneway through design articulation, fenestration, materials, colours, major opening(s) and balconies, with no blank walls permitted facing any street boundaries. Corner building design (Lots 1, 9, 10 and 17) should be considered carefully to ensure continuity/harmony of materials and detailing to both street elevations. Lot 1 is designated as gateway status, and shall be designed to be unique and memorable with scale and proportion appropriate to the location and represent a point of difference to adjacent lots on this LDP (refer LDP Design Rationale attachment). At least one balcony of a minimum 10 m² is to be provided to the primary street elevation of each dwelling. Balconies provided to the secondary street on corner lots or overlooking the laneway are encouraged to achieve greater surveillance. Material and colour selection shall respond to the details incorporated in the Port Coogee Marina Village Built Form Codes and Port Coogee Marina Village Design Guidelines.
Wind	<ul style="list-style-type: none"> No wind assessment is required for buildings that accord with the building height and setback provisions on this LDP. Where buildings vary the provisions of this LDP, a wind assessment will be required in accordance with the PCMBVFC.
Designated Landscape Zone (laneway)	<ul style="list-style-type: none"> Where specified on the LDP (Lots 4-8 and 12, 14-16), a minimum 1.5m x 1.8m area shall be provided for soft landscaping, consisting of a range of groundcovers, shrubs or trees in accordance with a landscaping plan. For remaining lots, the Landscape Zone dimensions may be greater than 1.5m x 1.8m and are detailed further on the LDP Plan and within the LDP Design Rationale attachment. The Landscape Zone will satisfy the Deep Soil Area requirements where it achieves the minimum 1.5m dimension and any permeable paving is limited to a maximum 33% of the area (i.e., to achieve pedestrian access from the laneway). Where trees are provided by the developer within the Landscape Zone, no removal of the tree is to occur and the tree shall be maintained by the landowner.
Visual Privacy and Solar Access for Adjoining Sites	<ul style="list-style-type: none"> Visual privacy screening shall be provided to outdoor active habitable spaces (balcony and/or roof terrace) to restrict views within the cone of vision in accordance with the requirements of the R-Codes for the R60 density. In other circumstances, the City may vary the visual privacy provisions for adjoining sites within this LDP.
External Features, Utilities and Facilities (Incidental development requirements)	<ul style="list-style-type: none"> Clothes Drying Area: A minimum 4m² area shall be provided in a single location or the area split into multiple locations where a minimum dimension of 1.5m. Screening to the clothes drying area shall be provided in any instance where visible from the public realm. Storage Area: A minimum 4m² area shall be provided on the ground floor with a minimum dimension of 1.0m and shall not be impeded by any door or its swing. Where located external to the building/garage, the storage shall be enclosed. Rubbish Bins: For all lots, rubbish bins must be located on the driveway for their waste collection day if no adjacent verge space is available. A rubbish storage area shall be provided that is screened from view of the public realm at all times, other than collection day. Parapet Walls: Any exposed parapet wall on a common boundary must be suitably finished to match the external walls of the building, unless otherwise approved by the City.
Other	<ul style="list-style-type: none"> Notification that future development adjoining this LDP will contain land uses and activities that may generate noise in keeping with a vibrant mixed-use precinct as described within the PCMBVFC. All Development Applications will require prior developer's endorsement to be provided upon lodgement with the City.

Legend

- █ Extent of Local Development Plan
- █ No Vehicle Access Permitted
- Building Envelope - all levels permitted (See Design Rationale for further detail)
- Extent of Uniform Boundary Fencing (Developer Provided)
- Designated Garage Location
- Nil Building Setback Permitted
- Designated Landscape Zone

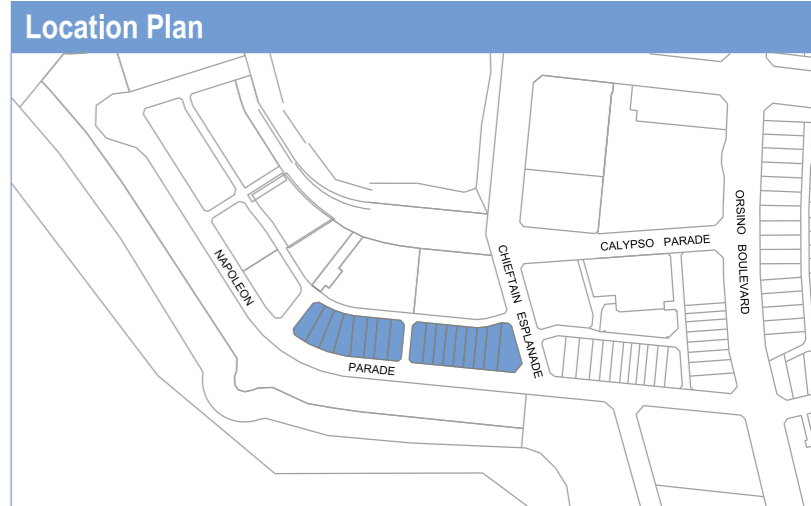

Future Development (Not subject of this LDP)

Future Development (Not subject of this LDP)

Future Development (Not subject of this LDP)

Opal Lane (Secondary Frontage)

Liberty Vista

Saxon Lane

Chieftain Esplanade

Napoleon Parade

Primary Frontage

Primary Frontage

Secondary Frontage

Foreshore Reserve

CITY OF COCKBURN

LOCAL DEVELOPMENT PLAN

APPROVED

09 Nov 2022

File Ref: LDP22/23

Plan 1 of 1

Local Development Plan - Site Specific Building Requirements - Lots 1 - 17

OMEOPENINSULA, PORT COOGEE MARINA VILLAGE

A Frasers Property Project

scale:
1:1000@A3 | 1:500@A1

0 10 20m

plan:
90/057/409M

date:
7/11/2022

Taylor Burrell Barnett Town Planning & Design
Level 7, 160 St Georges Terrace, Perth WA 6000
e: admin@tbbplanning.com.au
p: (08) 9226 4276



© COPYRIGHT TAYLOR BURRELL BARNETT. ALL RIGHTS RESERVED. ALL AREAS AND DIMENSIONS DISPLAYED ARE SUBJECT TO DETAIL SURVEY.

A Building Envelope - Design Fundamentals

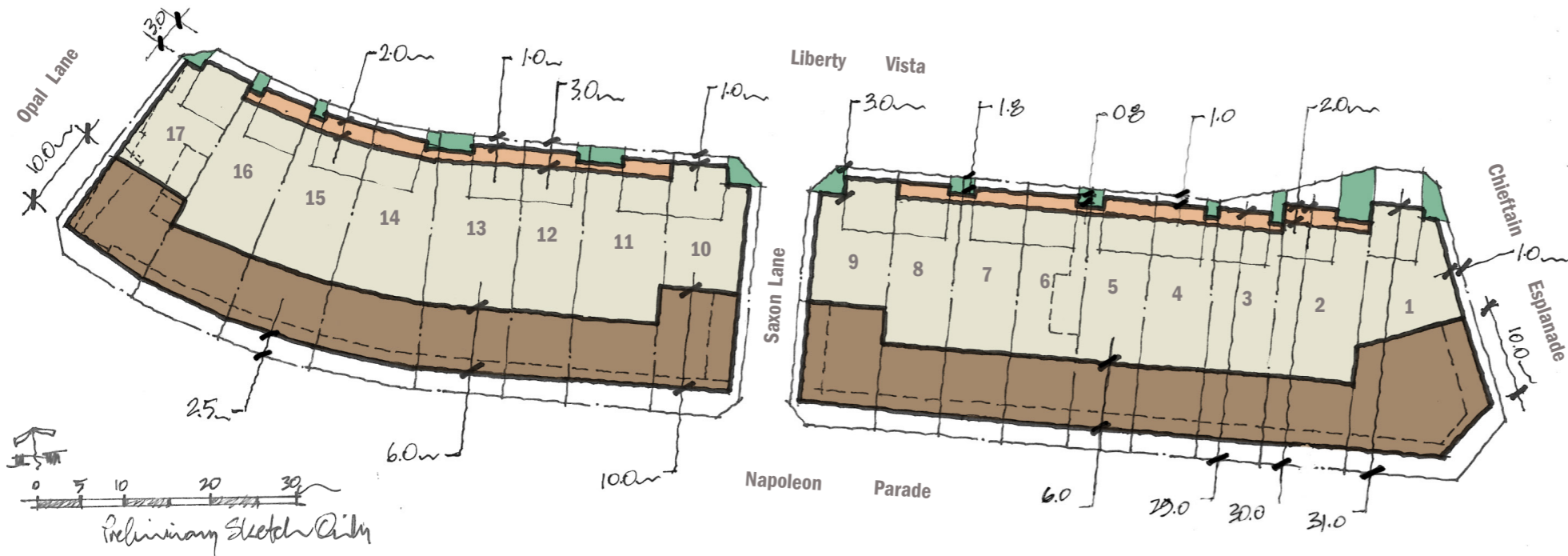

Consolidated Building Envelope Illustration for Street Setbacks - All Levels

- Ground Level - Maximum Building Envelope (minimum street setback)
- Second Level - Minimum Building Envelope (Lots 1, 9, 10 and 17)
Preferred Building Envelope (Lots 2-8 and 11-16)
- Third Level - Minimum Building Envelope requirement
- Designated Landscape Zone - Minimum requirement

• This is an illustration of the 'layered' building envelope areas to be considered as a result of the minimum and maximum street setbacks permitted on the LDP.

Minimum Building Envelope - Street Setback Illustration

Ground Level Only - Maximum street setback

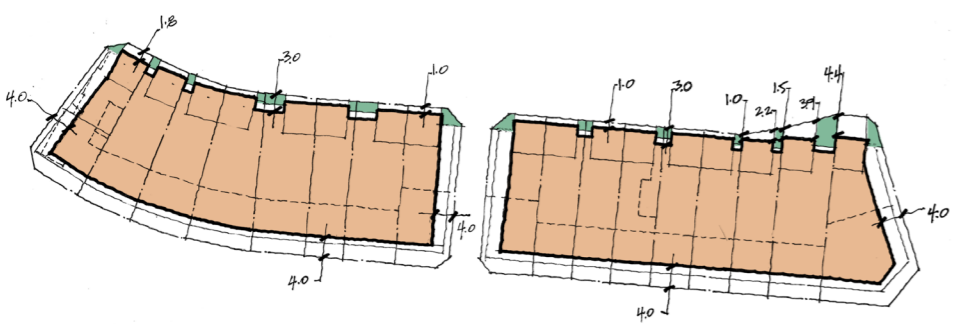

- The minimum indicative ground level building envelopes are determined by the maximum Primary Street and Secondary Street setback (4.0m) and the laneway mandatory setback for garages (1.0m). A landscape zone is designated adjacent the laneway which determines the ground level dwelling and fence setbacks / building envelope (typically 1.8m).
- Minimum building side setbacks of 0.0m are permitted (subject to open space and landscape requirements being achieved).

Maximum Building Envelope - Street Setback Illustration

Ground Level Only - Minimum street setback

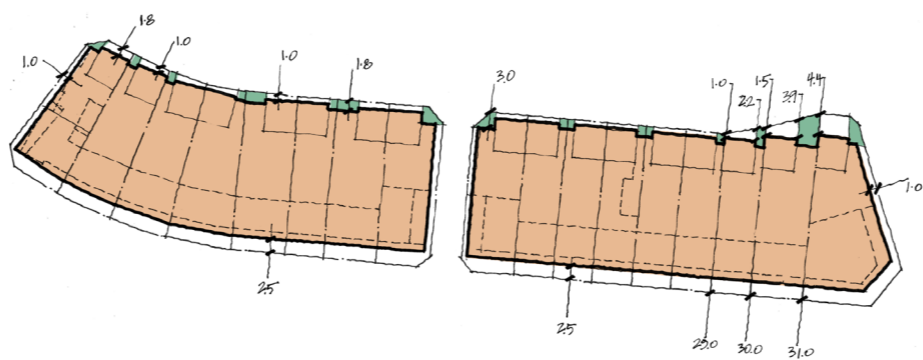

- The maximum indicative building envelopes for all levels of development are determined by the minimum Primary Street and Secondary Street setback (2.5m) and the mandatory (ground) and minimum (upper) laneway setbacks (1.0m). A landscape zone is designated adjacent the laneway which determines the ground level dwelling and fence setbacks / building envelope (typically 1.8m).
- Minimum building side setbacks of 0.0m are permitted (subject to open space and landscape requirements being achieved).

Hypothetical Development Illustration - Responding to Permitted Building Envelope(s) - All Levels

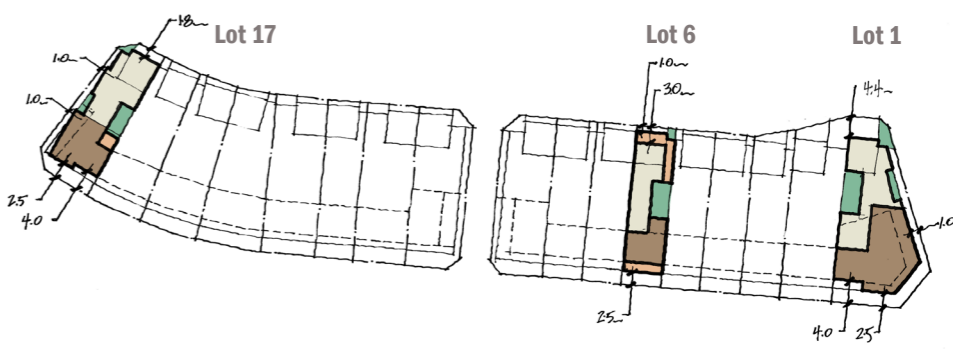

- This hypothetical development illustration indicates the location and extent of ground and upper level development that responds to the minimum and maximum street and lot boundary setbacks that are detailed on the LDP.
- Further detailed explanation of the above illustration of example Lots 1, 6 and 17 are included at pages 2 and 3 of this Design Rationale package.



B Building Envelope - Design Fundamentals for Typical Lot (Lots 2-8 and 11-16)

Minimum Building Envelope Setback Illustration

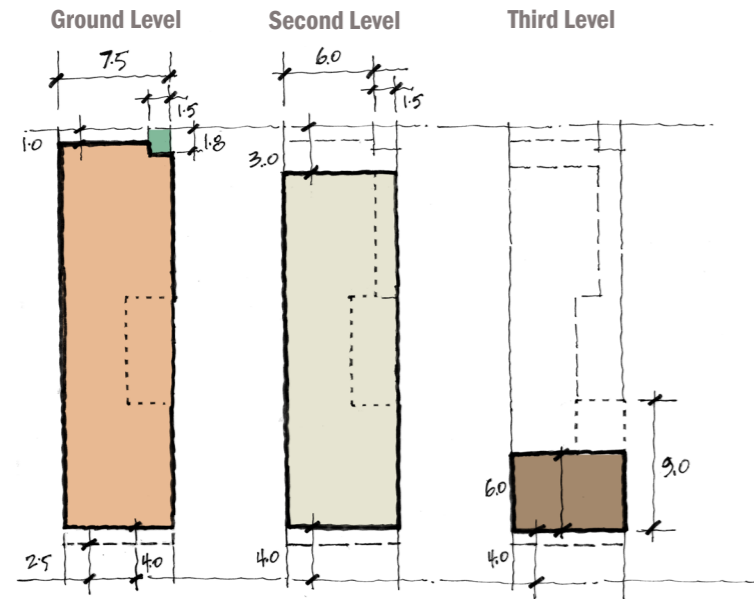

- The minimum indicative ground level building envelope is determined by the maximum Primary Street setback (4.0m) and the laneway mandatory setback (1.0m). Minimum building side setbacks of 0.0m are permitted (subject to open space and landscape requirements). A 1.5m x 1.8m landscape area is required, except where alternate dimensions are specified on the LDP (refer to LDP for applicable lots).
- The minimum indicative second level building envelope is determined by the maximum Primary Street setback (4.0m) and the preferred laneway setback (3.0m). The LDP provides flexible laneway setback options for the second level above the garage (1.0m minimum / no maximum), although the preferred building response is for a 3.0m maximum second level setback to achieve desirable surveillance outcomes and upper level building framing to the laneway - see page 4 of this rationale for more detail.
- Minimum building side setbacks of 0.0m are permitted (subject to open space and landscape requirements).
- The minimum indicative third level building envelope is determined by the maximum Primary Street setback (4.0m) and the minimum development depth (6.0m). Minimum building side setbacks of 0.0m are permitted.
- *Note: A minimum one (1) storey building height is permitted to portions of the building that are not visible from the primary street, but are permitted where they are internalised on the lot or visible from the laneway for lots 2-8 and 11-16 only)*

Maximum Building Envelope Setback Illustration

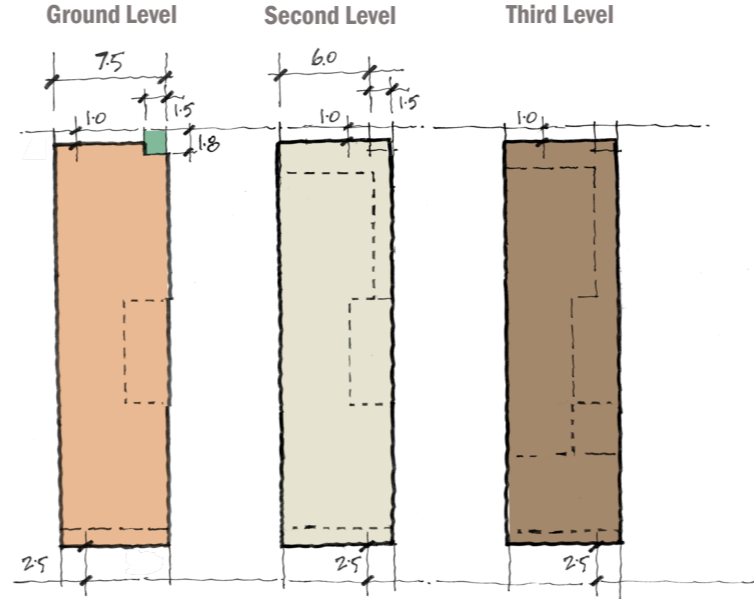

- The maximum indicative building envelope for all levels of development is determined by the minimum Primary Street setback (2.5m) and the mandatory (garage) and minimum (dwelling and fencing) laneway setbacks (1.0m).
- Minimum building side setbacks of 0.0m are permitted (subject to open space and landscape requirements). A 1.5m x 1.8m landscape area is required, except where alternate dimensions are specified on the LDP (refer to LDP for applicable lots).
- *Note: A minimum one (1) storey building height is permitted to portions of the building that are not visible from the primary street, but are permitted where they are internalised on the lot or visible from the laneway for lots 2-8 and 11-16 only)*

Hypothetical Development Illustration - Typical Lot

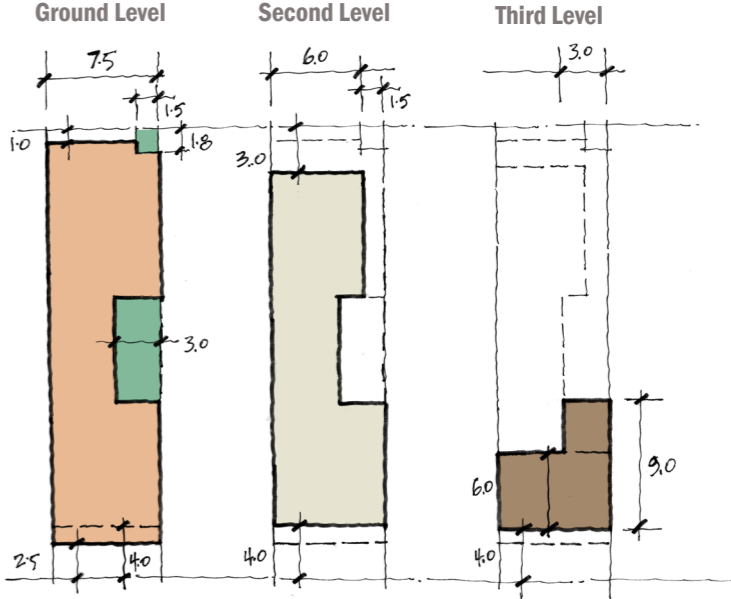

- A hypothetical development illustration achieves a ground level building envelope with a minimum Primary Street setback (2.5m) and the laneway mandatory garage setback (1.0m) and minimum dwelling setback (1.8m). Minimum building side setbacks of 0.0m are adopted to enable an inner courtyard (open to the sky), along with the 1.5m x 1.8m landscape area adjacent the laneway.
- The indicative second level building envelope achieves the maximum Primary Street setback (4.0m) and the preferred laneway setback (3.0m for 80% of building frontage). A combination of 0.0m side setbacks and upper level side setbacks from the LDP are utilised.
- The indicative third level building envelope achieves the maximum Primary Street setback (4.0m) and the LDP minimum depth requirement.

Hypothetical Development Section - Typical Lot

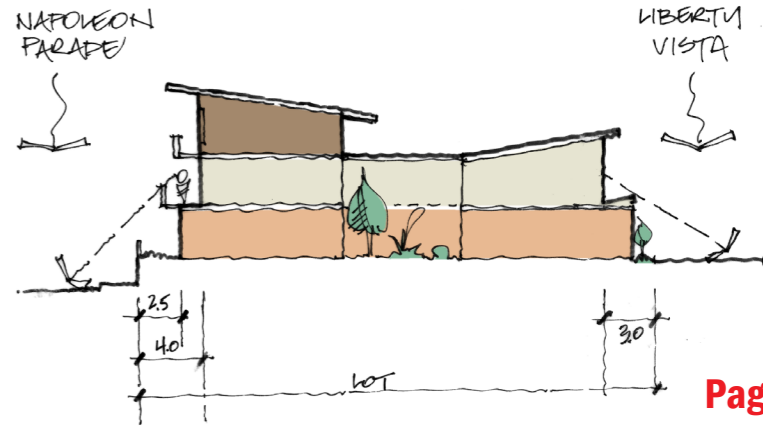

Plan Legend

- Ground Level
- Second Level
- Third Level
- Landscape



D Laneway Frontage Design Fundamentals - Setback Preferences (Lots 2-8 and 11-16)

Within the Port Coogee Marina Village, laneways are a vital component of the public realm network where pedestrians and vehicles share these spaces.

Whilst the LDP is flexible in its second and third level building setbacks from the laneway for the lots above (1.0m minimum/no maximum), the preferred building design response and principles are detailed below:

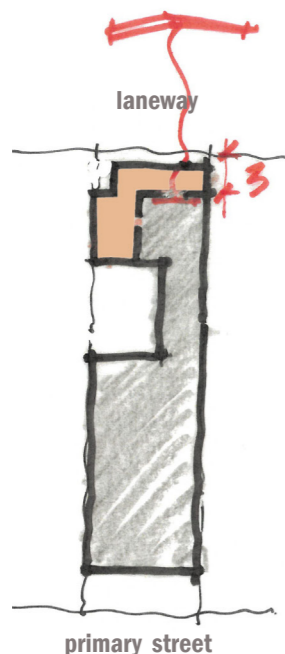

Upper Level Setbacks - Scenario 1

Where the second storey building frontage width is not 100% of the ground floor building frontage width at the laneway elevation, then the following is preferred:

- The minimum width of the upper storey building frontage should be 60% of the ground floor building frontage at the laneway elevation.
- To achieve this reduced upper storey building frontage, the upper floor habitable room should have a maximum setback of 3.0m, and incorporate a major opening (in that portion of wall at 3.0m setback) that achieves surveillance of the laneway road surface.
- A balcony or roof terrace is preferred but not required to be provided. Where provided it should ideally have a maximum setback of 2.0m and minimum area of 6m².

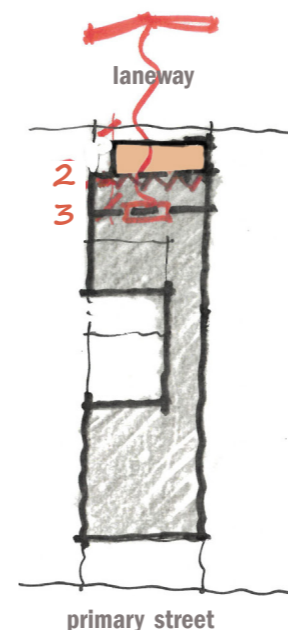

Upper Level Setbacks - Scenario 2

Where the second storey building frontage width is 100% of the ground floor building frontage width at the laneway elevation, then the following is preferred:

- The upper floor habitable room to ideally be setback from the laneway a maximum of 5.0m, where it incorporates a major opening that achieves surveillance of the laneway, and a balcony or roof terrace to be provided with a setback of 2.0m and minimum area of 10m².
- Roof cover to the balcony or roof terrace is preferred to achieve year-round use.
- Boundary walls would be permitted to enclose the sides of the balcony/roof terrace in the instance where support for a roof above is required and visual privacy screening is necessary.

Plan Key:

- Buff colour represents ground floor
- Grey colour represents upper floors
- Red solid line represents major opening(s)

E Laneway Frontage Design Fundamentals - Indicative Sections

Prioritise built form framing, activation and surveillance

Hypothetical Development Response - Minimum LDP Setbacks

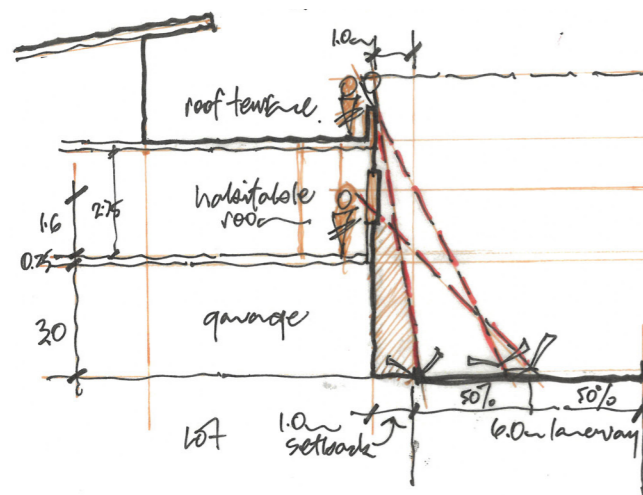

- Built form achieves 'Marina Village' appropriate design response of framing, massing, activation and articulation to the shared space laneway.
- Second level habitable room major opening maximises surveillance of the laneway.
- Third level roof terrace enhances northerly exposed indoor/outdoor living areas and surveillance of the laneway public realm.
- This design minimises potential CPTED viewing shadow.

Hypothetical Development Response - Preferred Scenario 1

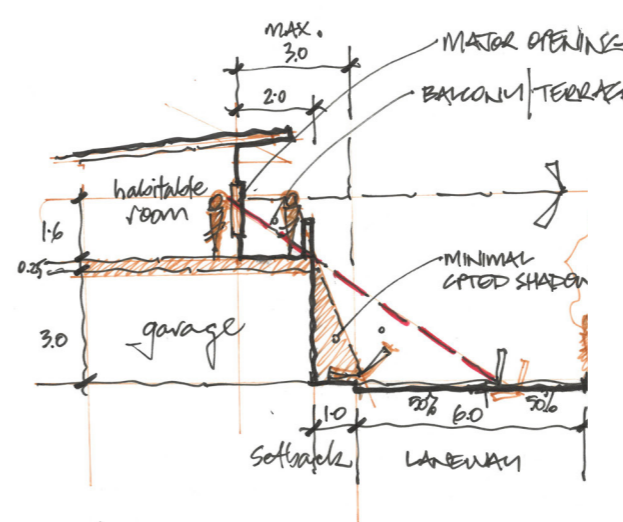

- Built form achieves 'Marina Village' appropriate design response of framing, massing, activation and articulation to the shared space laneway.
- Second level habitable room major opening achieves surveillance of a minimum 50% width of the laneway public realm.
- Desirable second level balcony enhances surveillance, indoor/outdoor liveability and activation of public realm.